

STOLZ

Pre cleaner Drum SEMC



ENGINEERED
TO YOUR NEEDS

The pre-cleaner is dedicated to the pre-cleaning of dry product (reception safety).

Located at the inlet of an installation, it removes all the foreign bodies which may be in cereals and flours.

With barley and winter barley, it breaks and removes a great part of silks on dry malt, it removes malt culms.

In most cases for high capacity receptions, the lump breaker ensures a proper preservation of the storage before going to the cleaner-separator.

FEATURES

- Continuous and smooth operation
- Operation without dust emission by air vacuuming
- Cleaning of high standard wastes with good product crossing the screens mesh
- Developing opening sections
- Interchangeable and easily dismountable screens

OPTIONS

- Discharge hopper for good product
- Intake hopper for coarse wastes

OPERATION

The cleaning of coarse wastes is obtained by the flow of good products into a drum **1** through the mesh of a rotary cylindrical screen.

The coarse grade products remain inside and are discharged at outlet **2**.

Fixed or progressive mesh opening.
Interchangeable and easily dismantlable screens.
Operation without dust emission by air vacuuming. **3**

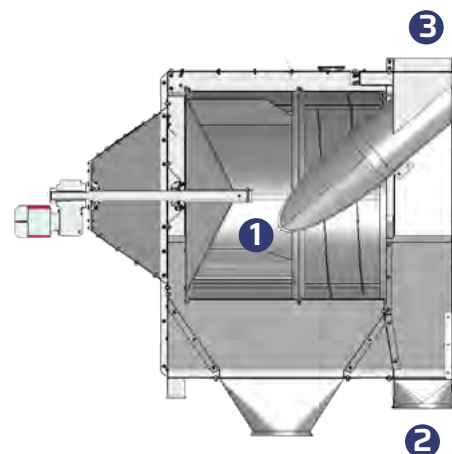

DIMENSIONS BY TYPE

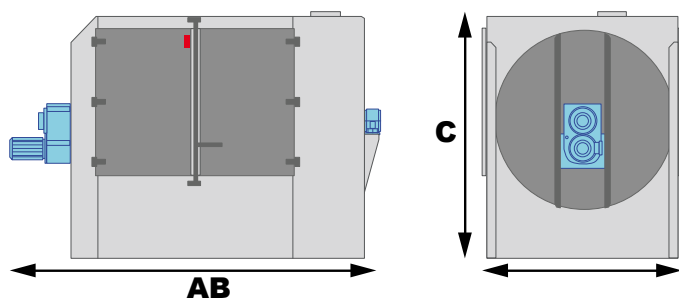

Type	Size (mm)			Weight kg
	A	B	C	
SEMC 750	1910	900	1550	470
SEMC 1250	2700	1490	2500	1125
SEMC 1600	3850	2110	2550	3900

GENERALLY REACHED CAPACITIES

Type	Wheat	Dry corn	Wet corn	Barley	Sunflower	Rapeseed	Soybean	Cocoa
	SW 0.75	SW 0.75	SW 0.73	SW 0.7	SW 0.4	SW 0.6	SW 0.7	
	H14%	H15%	H35%	H12%	H12%	H12%	H12%	
SEMC 750	60 t/h	60 t/h	35 t/h	55 t/h	30 t/h	40 t/h	30 t/h	20 t/h
SEMC 1250	200 t/h	200 t/h	100 t/h	150/180 t/h	100 t/h	120 t/h	100 t/h	60 t/h
SEMC 1600	300/400 t/h	250/350 t/h	200 t/h	350 t/h	200 t/h	180 t/h	160 t/h	120 t/h

STOLZ

82 Route de Boisjean • 62170 • Wailly Beaucamp • France
Tél : +33 (0)3 21 90 05 05 • contact.stolz@desmet.com
www.desmet.com/stolz
 /Stolz