

# STOLZ

## Plane sifters

PTAG

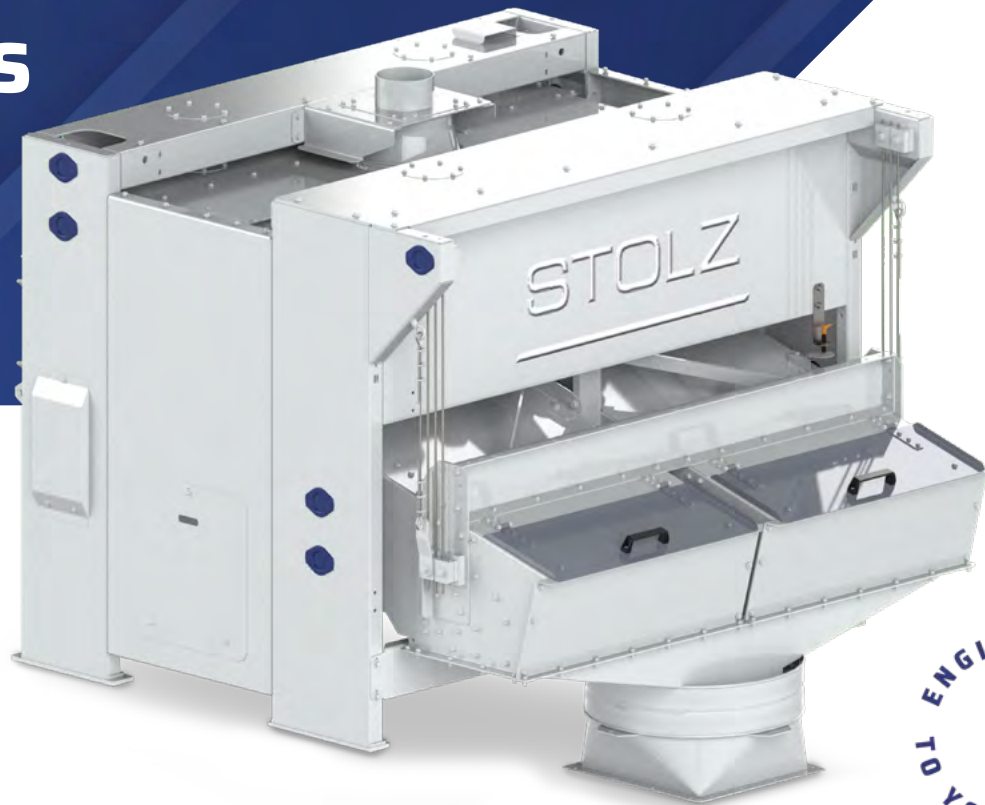

ENGINEERED  
TO YOUR NEEDS

The PTAG sifter is designed to collect the fines from the pellets to improve the quality of the final product. These fines are redirected to the pellet mill in order to limit product wastes.

The PTAG sifter is based on the principle of suspended casing moved by a circular and horizontal movement.

This sifter is mainly used to process products dedicated to animal feeding and other applications are possible.

The size of the processed products may vary from 0.5 mm to 25 mm.

The movement stroke is adjustable, enabling the linear speed of the product to be adapted.

### FEATURES

- Specific self-balancing system to optimize the product distribution while reducing the dynamic stress.
- Sieve drawer system
- Suitable to all particle sizes from large pellets to small crumbs.
- Discharge sieved product are directed to a mono or multi directional box with flexible circular connection.
- Low pressure inside the machine recommended.
- Also available with a crumbler built-in at sifter inlet.
- Two-part screen: Mesh holder and ball holder

## OPERATING PRINCIPLE

The product is introduced into the sifter into a distribution casing. The inclined bottom ensures the layering to the sieving unit.

The whole unit is moved by a horizontal circular movement. The sieving casing contain 1 to 3 screen levels.

The finest products flow through the screens. Weighted balls ensure the cleaning of screens.

Upper screens are followed by a lump breaking screen to remove the large wastes.

Calibrated products are driven to a four-compartment centering hopper.

An outlet connected to the floor ensures the connection to the downstream installation.

As an option a suction inlet can be provided with that equipment.

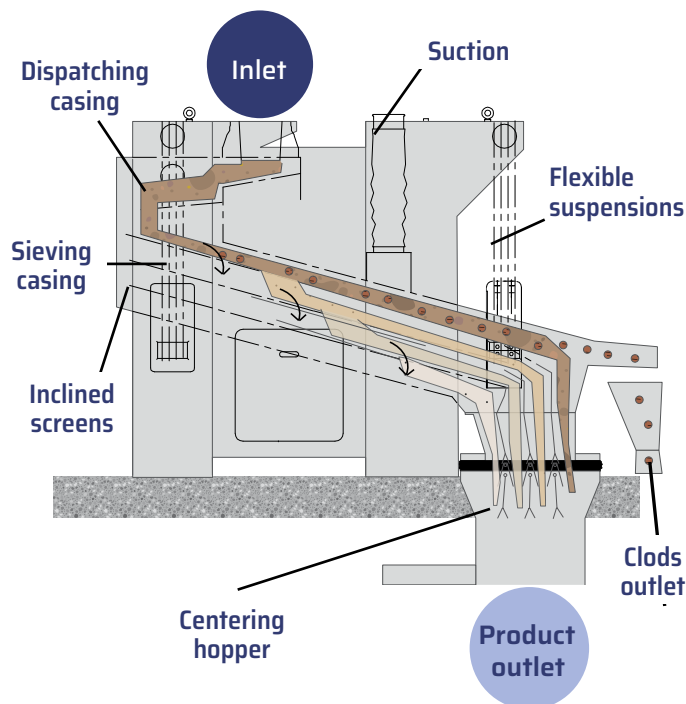

## BOXES UNDER SIFTERS

The PBSS box fitted at sifter outlet is designed to adjust to the various combinations of a manufacturing diagram thanks to the adjustment of 2 flaps.

The 2 flaps are driven by pneumatic cylinders. There are 9 possible combinations.

The control is provided by distributors driven by solenoid valves.

The position monitoring is carried out by inductive sensors fitted on sides.

Range	Type	Capacity on pellet SW 0.5	Number of cuts	Working area
PTAG 306	PTAG-1 102	10 T/h	1	2 m <sup>2</sup>
	PTAG-1 204		2	4 m <sup>2</sup>
	PTAG-1 306		3	6 m <sup>2</sup>
	PTAG-2 104	20 T/h	1	4 m <sup>2</sup>
PTAG 312	PTAG-1 104	20 T/h	1	4 m <sup>2</sup>
	PTAG-1 208		2	8 m <sup>2</sup>
	PTAG 1-312		3	12 m <sup>2</sup>
	PTAG-2 108	35 à 40 T/h	1	8 m <sup>2</sup>
PTAG 2 216	PTAG-2 216	40 T/h	2	16 m <sup>2</sup>
PTAG 2 324	PTAG-2 324	40 T/h	3	24 m <sup>2</sup>
PTAG 3 230	PTAG-3 115	60 T/h	1	14,4 m <sup>2</sup>
	PTAG-2 230		2	28,8 m <sup>2</sup>

# STOLZ

82 Route de Boisjean • 62170 • Wailly Beaucamp • France

Tél : +33 (0)3 21 90 05 05 • contact.stolz@desmet.com

www.desmet.com/stolz

/Stolz