

# STOLZ

## Molasse Mixer RM-CP

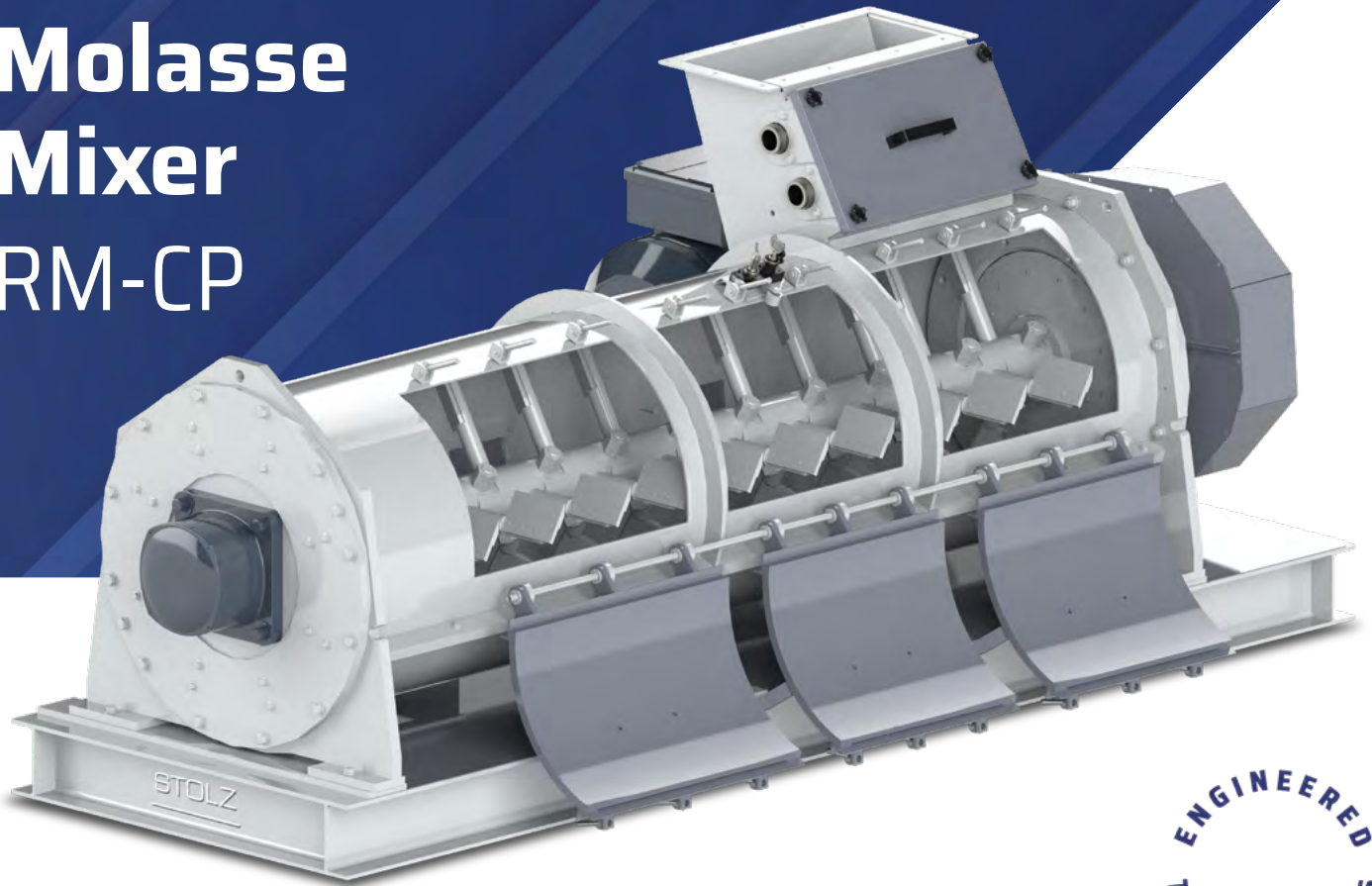

ENGINEERED  
TO  
YOUR NEEDS

STOLZ Molasse mixer is mostly used for molasse incorporation (up to 8% in the mealy products for livestock feed).

Standard steel construction with HD 1000 polyethylene liner or stainless steel body construction.

It may be :

- Used as a conditioner before a pellet mill or a maturing machine with a liquid incorporation greater than 3%.  
Such equipment is made of mixed stainless steel-steel (stainless steel body).
- Used as a mixer and lump breaker.
- Used as a continuous mixer.

### FEATURES

- Molassing chamber provided with wide opening access doors.
- Non-stick internal coating
- High molasse dispersion level due to high rotation speed.
- Dynamically balanced rotors
- Tungsten carbide-treated or hardened steel blades
- Possible simultaneous spraying of 1 to 3 different liquids
- Support base with shock absorber

## LIQUIDS INCORPORATION

Liquids incorporation is done using a rack made from hollow pipes including screwed tappings, limiting partly the gravitary flow and including a «Flatjet» nozzle or a welded baffle at the ending.

The pipes are partitioned, which means that for each of the two liquids to be incorporated, 3 levels of flow rate are possible (small, medium or large). They include a flexible device at each end (1 m to 1.5 m long, according to type) which must be connected to the the set of incorporation equipment in order to avoid gravity flow.

A pneumatic bleed at the end of batch to stop instantaneously the liquids flows must be provided.



Inside the mixer

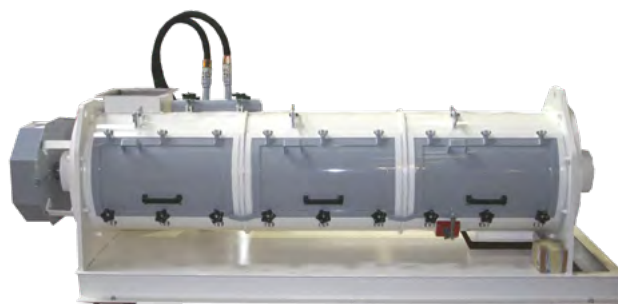

Molasse mixer side view

## DIMENSIONS AND POWER BY TYPE

Type	Nominal Capacity	Diameter	Overall dimensions (mm)			Weight	Installed power
	t/h		mm	Length	Width		
RM-CP 2F	20	456	3450	750	800	1200	30
RM-CP 3E	30	620	2655	1635	1285	1600	37
RM-CP 4E	40	620	3170	1635	1285	1770	45
RM-CP 6E	60	740	3300	1970	1130	2700	75
RM-CP 8E	80	850	3425	2330	1500	4100	90
RM-CP 10E	100	850	3425	2330	1500	4100	110

# STOLZ

82 Route de Boisjean • 62170 • Wailly Beaucamp • France

Tél : +33 (0)3 21 90 05 05 • [contact.stolz@desmet.com](mailto:contact.stolz@desmet.com)

[www.desmet.com/stolz](http://www.desmet.com/stolz)

 /Stolz